



Black Max™ Amplifier

X300, X450, & X600 Models

Installation and Use Manual

Notice

Every effort was made to ensure that the information in this guide was complete and accurate at the time of printing. However, information is subject to change.

Important Safety Information

WARNING: To Reduce The Risk of Fire Or Electric Shock, Do Not Expose This Apparatus To Rain Or Moisture.

Always follow these basic safety precautions when installing and using the unit:

1. Read these instructions.
2. Keep these instructions.
3. Heed all warnings.
4. Follow all instructions.
5. Do not use this apparatus near water. The apparatus shall not be exposed to dripping or splashing and no objects filled with liquids, such as vases, shall be placed on the apparatus.
6. Clean only with dry cloth.
7. **DO NOT** block any ventilation openings. Install in accordance with the manufacturer's instructions.
8. Do not install near any heat sources such as radiators, heat registers, stoves, or other apparatus (including amplifiers) that produce heat.
9. Do not defeat the safety purpose of the polarized or grounding-type plug. A polarized plug has two blades with one wider than the other. A grounding-type plug has two blades and a third grounding prong. The wide blade, or the third prong, are provided for your safety. If the provided plug does not fit into your outlet, consult an electrician for replacement of the obsolete outlet.
10. Protect the power cord from being walked on or pinched, particularly at plugs, convenience receptacles, and the point where they exit from the apparatus.
11. Only use attachments/accessories specified by the manufacturer.
12. Unplug this apparatus during lightning storms or when unused for long periods of time.
13. Refer all servicing to qualified service personnel. Servicing is required when the apparatus has been damaged in any way, such as power-supply cord or plug is damaged, liquid has been spilled or objects have fallen into the apparatus, the apparatus has been exposed to rain or moisture, does not operate normally, or has been dropped.

Domestic and International Listings

UL and C-UL Listed.

IMPORTANT



CAUTION: TO PREVENT THE RISK OF ELECTRIC SHOCK, DO NOT REMOVE COVER (OR BACK). NO USER-SERVICEABLE PARTS INSIDE. REFER SERVICING TO QUALIFIED PERSONNEL.

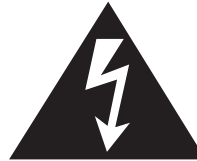

The lightning flash with arrow-head symbol, within an equilateral triangle, is intended to alert the user to the presence of uninsulated "dangerous voltage" within the product's enclosure that may be of sufficient magnitude to constitute a risk of electric shock to persons.



The exclamation point within an equilateral triangle is intended to alert the user to the presence of important operating and maintenance (servicing) instructions in the literature accompanying the appliance.

Contents

	Page
INTRODUCTION	1
Package Contents	1
PANEL DESCRIPTIONS	2-3
Black Max Front Panel.....	2
Black Max Rear Panel.....	3
INSTALLATION	4-5
Mechanical Components.....	4
Ventilation.....	5
Rack Mounting.....	5
Rear Rack Mounting.....	5
Table Mounting	5
CONNECTIONS	6
Speakers	6
Inputs	6
AC Power.....	6
SEQUENTIAL TURN-ON	7
Sequential Turn-On Operation	7
OPERATION	8-9
Front Controls & Indicators	8
Rear Controls & Indicators	8
TROUBLESHOOTING	10
SPECIFICATIONS	11
LIMITED WARRANTY; EXCLUSION OF CERTAIN DAMAGES	12

Introduction

Bogen's Black Max™ amplifiers deliver on what professional sound installers need most: Power and Reliability.

Power

With three different models (X600, X450, and X300), the Black Max series provides 2 independent channels of amplification at 600W, 450W, and 300W per channel into 70V constant-voltage speaker loads safely and securely. Located on the rear of the amplifier are the Level Controls, Low Cut Filter Switch, and pluggable input terminal strip for each amplifier channel. These amplifiers are powerful (with total system power of 1200W, 900W and 600W with both channels driven), but they are also compact — using up only 2 rack spaces (3-1/2") in a standard 19" rack.

Reliability and Functionality

Driven by a conservatively-rated toroidal power transformer, these amplifiers are built for solid performance with low distortion and a high slew rate. The amplifiers require little maintenance and cleaning as internal electronic components are located outside of the forced air stream flow. Front-mounted fan filters provide easy removal and cleaning.

Black Max amplifiers have a variety of electronic protection circuits including overcurrent, DC voltage, and thermal circuits. A special Clip/Limiting circuit continuously monitors the amount of distortion in the output signal and reduces input levels as the amplifier approaches clipping. Back-Slope™ AC Voltage Stabilization, Bogen's unique voltage stabilization circuitry, regulates the AC energy supplied from the power toroid. This improves both system performance and reliability despite varying AC supply conditions.

An energy-conserving sleep mode (defeatable) with instant-on return signal operation reduces wasted heat production in paging systems with intermittent use. In addition, large output heat sinks and dual independently-controlled, high-output, variable speed fans provide superior cooling and quiet operation while reducing dust accumulation.

A simple and reliable sequential turn-on feature minimizes in-rush current from the AC power mains. When multiple Black Max amplifiers are daisy-chained together for sequential turn-on, the first amplifier in the series will control the powering up of the other amplifiers with approximately 1 second of delay between units. Turning off the first amplifier causes all amplifiers to turn off.

Package Contents

- * Black Max Amplifier (Model X600, X450, or X300)
- * 2 Filters and Grilles
- * 4 Rubber Feet & Screws
- * 2 Rack Ears for Mounting
- * Instruction Manual
- * 2 Three-position, 1 Four-position Terminal Strips

Panel Descriptions

Black Max Front Panel

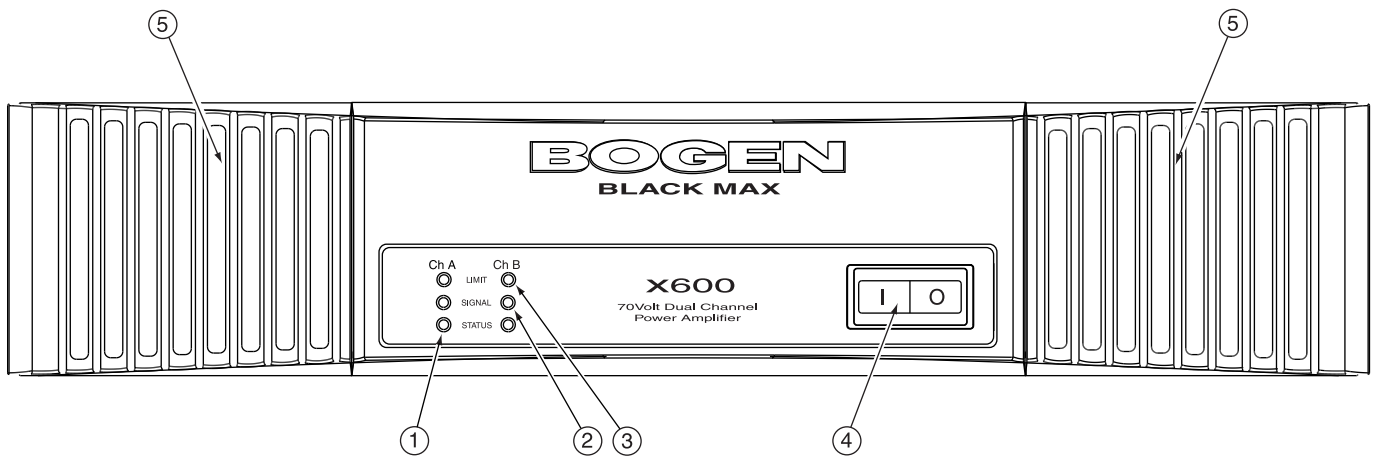

- 1. Status Indicators** - The Status LEDs are multi-purpose indicators, one for each channel.
Green - Amplifier is on and operating normally.
Amber - Amplifier is in low-power consumption Sleep Mode.
Red - Amplifier has protected itself due to a fault condition.
- 2. Signal Indicators** - These illuminate green when signal is present at the output, one for each channel.
- 3. Limit Indicators** - These indicators illuminate amber when excessive signal levels or very low impedance output loads cause output distortion to exceed a few percent. Under such conditions, a built-in Clip/Limiting circuit activates and reduces input signal levels to protect both amplifier and speaker loads. One for each channel.
- 4. Power Switch/Circuit Breaker** - Magnetic circuit breaker controls AC power to the amplifier.
- 5. Fan Air Intake and Grilles** - Air intakes for 2 independent, variable-speed cooling fans. Each responds as needed to keep the amplifier cool while reducing dust build-up. Removable fan grilles are provided to allow access to the dust filters for cleaning.

Panel Descriptions

Black Max Rear Panel

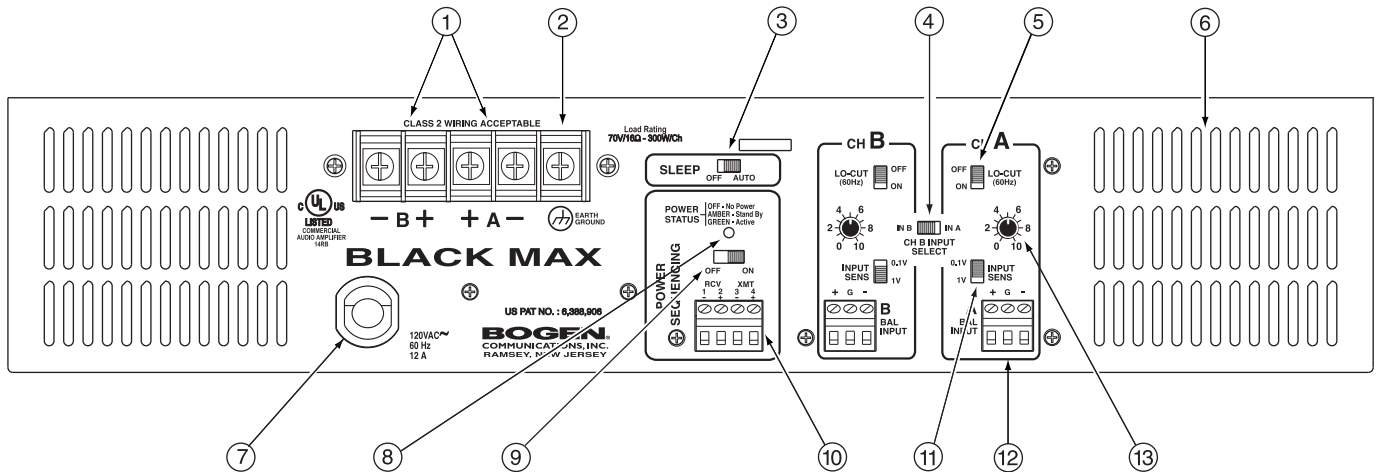

- 1. Speaker Terminals** - Connects to 70V constant voltage speaker loads. One set for each amplifier section. Accepts up to #10 AWG wire or spade lugs for speaker system connections.
- 2. Ground Terminal** - Provides convenient access to earth ground.
- 3. Automatic Sleep Mode** - Allows the unit to automatically put itself into a sleep mode when there has been no input activity for more than 3 minutes. In sleep mode, the amplifier's idle power is greatly reduced. The amplifier immediately and noiselessly returns to its full-powered state when a signal is detected at an input. Flush switch actuators reduce tampering.
- 4. CH B Input Select Switch** - Allows output Channel B to source its input signal from either "A BAL INPUT" or "B BAL INPUT".
- 5. Lo-Cut Filters** - Roll off frequencies below 60 Hz (2nd order) to prevent saturation of speaker transformers. Flush switch actuators reduce tampering. One per channel, high pass.
- 6. Fan Exhausts** - Cooling air outlets for independent, variable speed cooling fans. One per channel.
- 7. Line Cord** - AC mains input line cord. **Note:** The X600 requires a 20A, 125V AC power receptacle because its maximum current requirements exceed the capacity of a typical 15A receptacle. The 20A receptacle is a NEMA 5-20R style.
- 8. AC Power Status Indicator** - Indicates the AC power status of the Black Max amplifier. When the indicator is not lit, no AC power is applied to the line cord. When lit amber, power is applied to the line cord but no sequential trigger has been received to place the amplifier into a fully powered-up state (or power switch is OFF). When lit green, the amplifier is fully powered.
- 9. Power Sequencing Switch** - Turns power sequencing ON or OFF so that an amplifier can be controlled by either its front circuit breaker switch or by another Black Max amplifier. Flush switch actuators reduce tampering.
- 10. Power Sequencing Inputs** - Multiple Black Max amplifiers can be wired together in a daisy chain to allow for controlled sequential power-up. A pluggable screw terminal strip is provided for easy installation.
- 11. Input Sensitivity Switch** - Allows the unit to reach full power at either line-level input (1V) or low-level input (0.1V). One per channel.
- 12. High-Impedance Balanced Inputs** - Pluggable 3-position screw terminal strips allow for easy installation and provide convenient connections to high-impedance balanced inputs. One per channel.
- 13. Input Level Controls** - Continuously variable input level controls. One per channel.

Installation

Mechanical Components

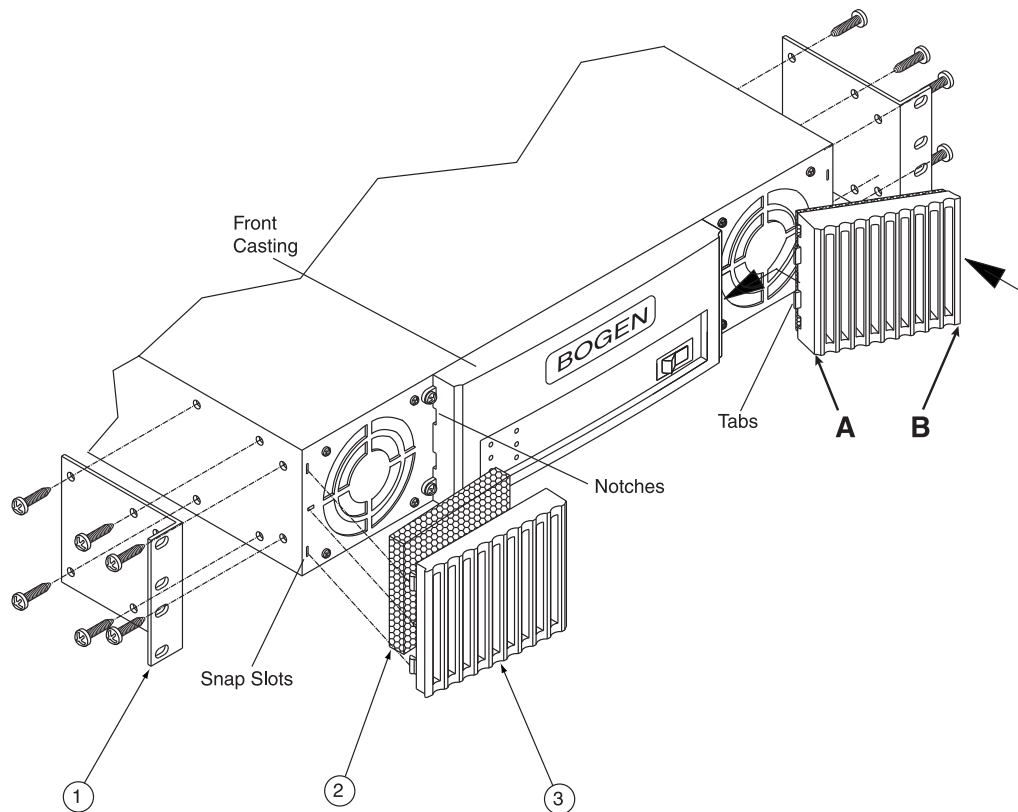

1. **Rack Ears** - Prior to installing the amplifier into a 19" rack, you will need to attach the rack ears. Remove and save the 6 front-most cover screws on each side panel of the amplifier. Position the rack ears as shown and attach using the 6 screws.
2. **Dust Filter** - Insert the dust filter into the fan grille before attaching the fan grille to the amplifier.

Filter Maintenance

Dust filters are provided with the Black Max amplifier to reduce the build up of dust on the heat sinks. Periodic cleaning should be done when there is a noticeable build up of dust on the filters. To clean the filters, remove them from the grilles and wash, vacuum, or tap them out. Promptly replace them.

Caution: *The fan blades are accessible when the grille cover and filter are removed. Be careful not to place your finger or other objects into the fan.*

3. **Fan Grille** - To attach the fan grilles: first, slide the tabs on the wider end of the grille (A) in to the notches in the front, center casting of the amplifier. Snap the other end of the grille (B) in to the snap slots. Check that the grille is securely in place. To remove, pry the end of the cover closest to the rack ears up until the snap tabs disengage.

Installation

Ventilation

The Black Max amplifiers were designed to be placed on a table or rack-mounted. For rack-mounted applications, the amplifiers can be stacked one on top of the other for maximum use of the rack space available without any extra, empty rack spaces between them.

An open air space of at least 4" must be provided at the front air intakes of the amplifier and the rear exhaust must have at least 4" between itself and obstructions to ensure adequate cooling. **This applies whether rack- or table-mounted.**

Care should also be taken to ensure that the front intake air is not considerably warmer than the ambient air temperature. Mount the amplifiers low in the rack so that heat dissipation from other equipment does not warm the amplifier's intake air.

Rack Mounting

Rack ears are included with the amplifier to allow mounting in 19" racks. Attach the rack ears as shown in the *Mechanical Components* section. If any feet have been attached to the bottom of the amplifier, remove them. Load the amplifier into the rack and secure it to the rack with appropriate hardware (not included).

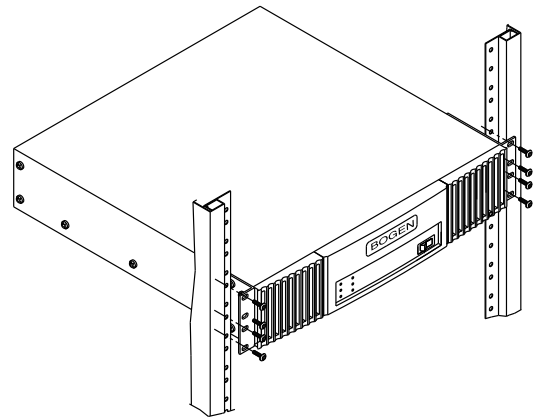

Rear Rack Mounting

(Optional accessory, not included)

For greater rear support when rack-mounting a Black Max amplifier, the RPK86 Rack Mounting Kit can be attached to the rear of the amplifier by following these steps:

1. Remove and save the three rear-most cover screws from the chassis side.
2. Position the rack attachment as shown.
3. Replace and tighten the three cover screws to secure the rack attachments.
4. Repeat on opposite side of amplifier.

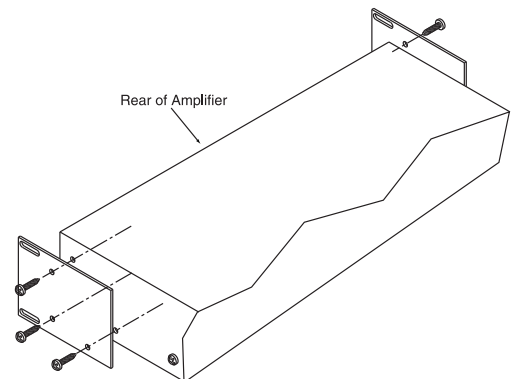
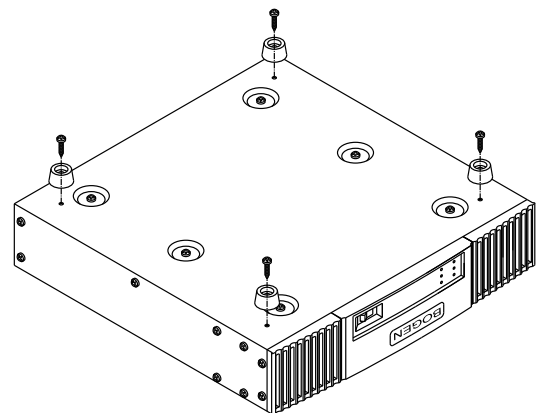

Table Mounting

Feet are provided with the amplifier to allow it to be placed on a tabletop. Attach the included feet to the bottom of the amplifier as shown. Attachment of the rack ears to the unit is optional and purely aesthetic.



Connections

Speakers

70V "Transformer-Coupled" Speakers

The Black Max series was designed to drive only 70V constant voltage type speaker loads. The use of low-impedance speakers may cause the amplifier to engage its protection circuits and shut down or limit amplifier function. The speaker terminals can accept up to a #10 AWG wire or spade lug and have integral clamping plates which make wiring easier. The polarity of each set of speaker outputs (A & B) is indicated with a "+" and "-" sign. Use these indicators to ensure that the phasing of the speakers are correct. Do not ground the "+" output of either set of outputs. Doing so will cause the amplifier to go into protect mode, shutting down operation of the affected channel.

Note: The "+" and "-" indicators are mirrored on "A" and "B" outputs. Be sure to make the correct connections.

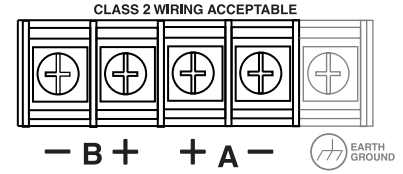

Earth Ground Terminal

The earth ground terminal is provided as a convenient means to connect to the amplifier's chassis/AC ground, if necessary. **DO NOT** connect the earth ground terminal to the "+" terminals of either output. No damage will occur if this is done, but the amplifier will go into protect mode and shut down the affected channel.

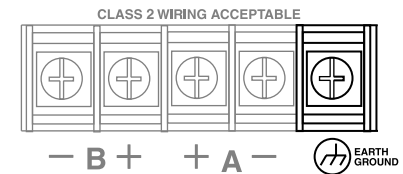

Inputs

Balanced Input Connections

Balanced input connections are used when the source device provides a balanced output (signal "+", signal "-", and ground "G"). This type of connection is desirable when operating in electrically noisy environments, where long input cable runs are needed, or to ensure the lowest noise operation. If compatible with the source device, this type of connection is recommended.

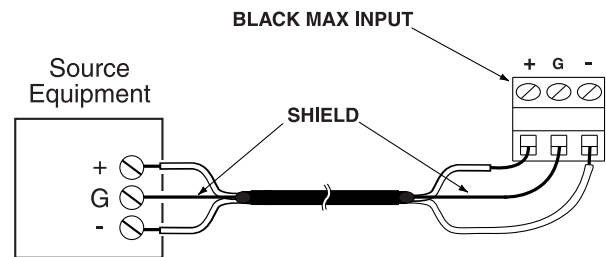

Unbalanced Input Connections

When the source device provides only an unbalanced output (signal and ground), the input should be wired with "-" input shorted to ground ("G"). The unbalanced signal's shield wire is connected to ground and the signal hot wire is connected to the "+" terminal. Since unbalanced connections do not provide the same amount of noise immunity that a balanced connection does, the connection distances should be made as short as possible.

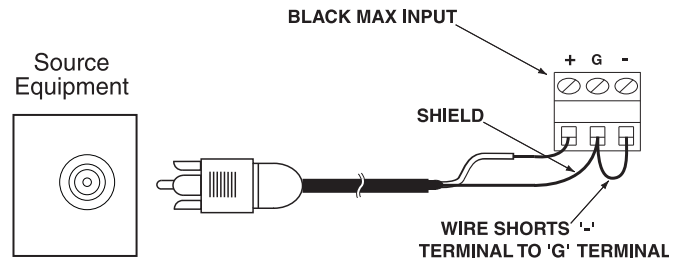

AC Power

20A AC Receptacle

The X600 line cord requires a 20A, 125V AC power receptacle because its maximum current requirements exceed the capacity of a typical 15A receptacle. The 20A receptacle is a NEMA 5-20R style.

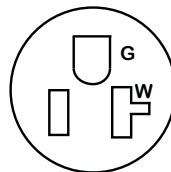

Sequential Turn-On

Sequential Turn-On Operation

Black Max amplifiers contain a sequential turn-on feature that is designed to turn on a bank of Black Max amplifiers, one at a time, in sequence with approximately 1 second between each amplifier. This type of sequencing of power is necessary in large systems where the in-rush current of all the system amplifiers turning on at once would overload the AC mains supplying the system.

The first amplifier in the chain will act as the master amplifier controlling the power-up for the group. When it is switched on, it will initiate the power-up sequence.

To prepare/wire multiple Black Max amplifiers for sequential turn-on operation, do the following:

Preparation & Wiring

Turn off all amplifiers and unplug from AC.

The amps should be wired together in a daisy chain fashion. Wire the XMT connections of one amp to the RCV connections of the next amp as shown in the diagram. This pattern is continued until all the desired amplifiers are connected. The last amplifier in the chain has no connections on its XMT terminals, and the first amplifier has no connection to its RCV terminals.

Note: The RCV and XMT terminals have both polarity and number indicators. In daisy chaining the amplifiers, the same connection pattern is used: Pin 4 ("+") XMT of the previous amp to Pin 2 ("+") RCV of the next amp and Pin 3 ("-") XMT of the previous amp to Pin 1 ("-") RCV of the next amp.

Switch Settings

The position of the Power Sequencing Switch of the Black Max is important in sequencing setup. The master amplifier's Power Sequencing Switch MUST be set to OFF. By setting the switch to OFF, this amplifier will turn on and off directly by its front Power Switch. All other amplifiers in the chain MUST have their Power Sequencing switches in the ON position so that they respond to the sequencing signals. All slave amplifiers MUST have their front Power Switch set to the ON position, with the exception of the master amplifier.

To Begin the Power Up Sequence

Turn on the first amplifier in the chain. All others will follow in sequence with a 1 second delay between them.

Power Down of Sequenced Amplifiers

When the first amplifier in the chain of sequenced amplifiers is switched off, all other amplifiers will also switch off immediately.

Troubleshooting Sequencing Problems

If an amplifier in the chain does not have its front Power Switch set to ON, it will not power up. However, all other amps that follow that amplifier will continue to sequence. If an amplifier in the chain does not have its Power Sequencing Switch in the ON position, it will break the daisy chain. It will, in effect, become a second master amplifier controlling all amps that follow it. In this case, if the Power Switch for this amp is switched off, the sequencing will stop at that amplifier. If this amplifier's Power Sequencing Switch is set to ON, then all amplifiers following it will have already begun to sequence.

Should an amplifier in the sequence shut off either by tripping its circuit breaker or by someone turning the Power Switch OFF, only that amplifier will lose power. All units that follow will remain powered up. If however, AC power is removed from an amplifier by unplugging the power cord, all other amps following it will immediately power down. An amplifier in the chain going into or coming out of low-power sleep mode will have no effect on the group.

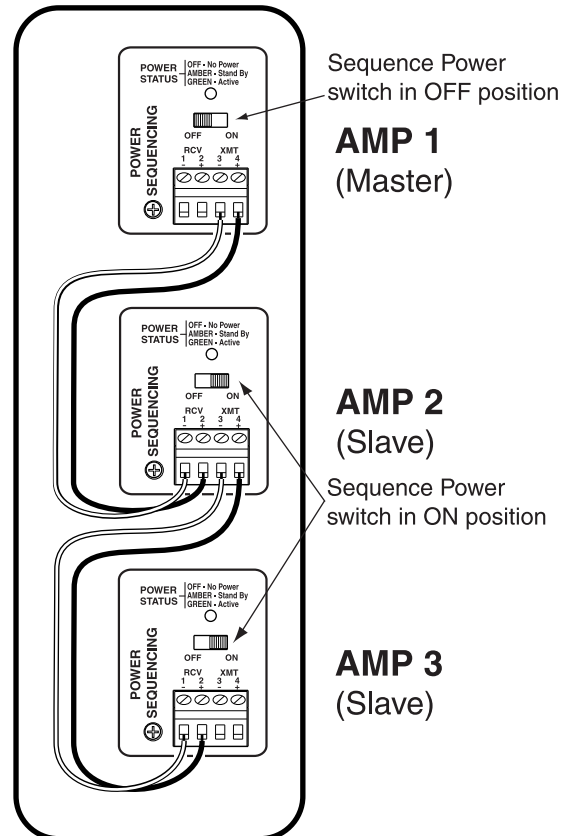

Operation

Front Controls & Indicators

Power Switch

The Power Switch for the Black Max amplifier is located on the front of the unit. Press the "I" side of the switch to turn the unit ON. The amplifier will begin its power-up process once turned on. If the amplifier is set up for power sequencing (see the section on power sequencing), the amplifier may not begin its power-up process but rather wait in a standby state until it receives a sequence trigger.

The Power Switch is also the amplifier's circuit breaker. Should the breaker trip, simply place it in the OFF position and then back to ON to reset the breaker.

Note: If the Power Sequencing Switch is in the ON position, but the wiring is not properly configured, the unit will appear dead. Review the Sequential Turn-On section for proper wiring.

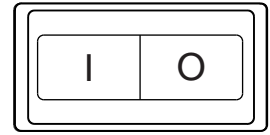

Front Indicators

The front of the Black Max amplifier contains 3 different types of indicators for each channel.

LIMIT - When illuminated, it indicates a condition in which the amplifier is limiting and automatically reducing signal level to reduce the overload condition. Limiting is a result of speaker load impedances that are too low or input signals that are too high, which drive the outputs beyond their operational ranges.

SIGNAL - When illuminated, it indicates that there is signal at the output.

STATUS - Illuminates in three different colors to indicate current operational status of the amplifier.

- Green - Indicates that the amplifier is operating normally.
- Amber - Indicates that the amplifier is in Sleep mode.
- Red - Indicates a fault condition and that the amplifier has disconnected the output load as a safety precaution.

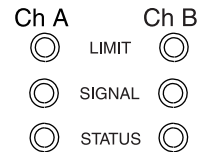

Rear Controls & Indicators

Level Controls

Use the rear-mounted Level Controls on the Black Max amplifier to adjust output volume of each channel independently.

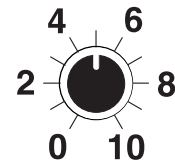

Lo-Cut Switch

The Low Cut Filter allows a low frequency roll-off starting at 60 Hz to be introduced into the signal path preventing the speakers from receiving too much low frequency content. The Low Cut Filter Switch should be turned ON when using typical inexpensive, transformer-coupled cone-type speakers found in paging systems.

The Black Max amplifier is a direct-coupled amplifier, which means that there are no output transformers used to deliver the 70V audio to the speakers. Because of this, the Black Max amplifier has a flat frequency response down to and below 20 Hz. This extended low frequency operation can be troublesome for some transformer-coupled speakers used in 70V audio systems. Relatively inexpensive transformers used in some speakers cannot handle frequencies below 60 Hz. When frequencies lower than this are applied to these speakers' transformers, they can saturate causing distortion and high instantaneous power consumption.



Sleep Switch

The Black Max amplifier includes a sleep mode feature that greatly reduces the power consumption of the amplifier after it has been idle (no audio activity) for more than 3 minutes. Any audio activity present at the input will power up the amplifier instantaneously and noiselessly, so that there is no loss of audio. The Sleep Switch is located on the rear of the unit. The sleep feature is activated by setting the switch to the AUTO position. Setting the switch to the OFF position will inhibit the amplifier from ever entering sleep mode.



Power Sequencing Switch

The setting of the Power Sequencing Switch on the rear of the Black Max amplifier determines how the amplifier will power up. When the switch is set to the OFF position, the amplifier will power up and down conventionally when the front Power Switch is turned ON and OFF.

To use the sequencing feature built into the amplifier, the Power Sequencing Switch must be placed in the ON position on a slave amplifier. The slave amplifier will now power up when it receives the proper trigger through the terminal strip wiring (see *Sequential Turn-On* section for proper wiring of the power sequencing terminal strip). With the Power Sequencing Switch in the ON position, placing the front Power Switch in the ON position will not result in the amplifier turning on. It will instead remain in a standby state until triggered through the sequencing feature.

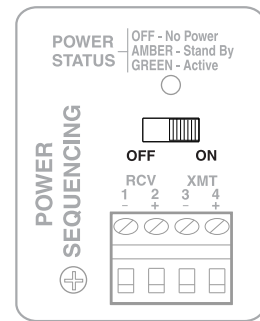

Power Status Indicator

A Power Status Indicator is provided on the rear of the amplifier. The Black Max amplifier has different states of powering up, depending on whether power sequencing is used or not. The Power Status Indicator provides 3 different status indications:

- Not Lit* - Indicates that the unit is not plugged in or is not being supplied AC power at the line cord.
- Amber* - Indicates that the unit is in standby state where it is being supplied with AC power at the line cord but it has either: 1) not received the sequencing trigger that will allow it to change to the fully-powered state if the Power Sequencing Switch is set to ON, or 2) the front Power Switch has not been turned ON if the Power Sequencing Switch is set to the OFF position.
- Green* - Fully-powered, the unit has either: 1) received the sequencing trigger if the Power Sequencing Switch is set to the ON position, or 2) the unit's front panel Power Switch has been turned ON if the Power Sequencing Switch is set to the OFF position.

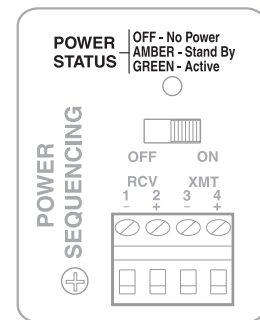

CH B Input Select Switch

Determines whether the amplifier's output channel 'B' sources its input signal from "B BAL INPUT" or "A BAL INPUT" connectors.

Note: When set to "INA", "B BAL INPUT" connector and CH B "Input Sens" Switch are not active, but CH B level control and Low Cut Switch are active.



Input Sensitivity Switch

Each input has a user-selectable sensitivity switch. When operating with standard line-level source equipment, the input should be set for 1V. When operating with low-level source equipment, the input should be set for 0.1V.



Troubleshooting

PROBLEM	CONDITION	CAUSE
UNIT APPEARS DEAD (NO FRONT STATUS LED)	Rear Power Status LED is off.	<ul style="list-style-type: none"> • Amplifier not plugged in • AC outlet dead
	Rear Power Status LED is amber.	<ul style="list-style-type: none"> • Power Switch OFF • Breaker (Power Switch) tripped <ul style="list-style-type: none"> - Turn off, then turn back on • Power Sequencing Switch set wrong <ul style="list-style-type: none"> - Check Sequential Turn-On section for proper configuration
SEQUENCING NOT FUNCTIONING CORRECTLY	Master amplifier ON (Rear Power Status is green), slave amplifiers in chain not powering ON (Rear Power Status is OFF).	<ul style="list-style-type: none"> • No AC power to amplifier
	Master amplifier ON (Rear Power Status is green), slave amplifiers in chain not powering ON (Rear Power Status is amber).	<ul style="list-style-type: none"> • Power Switch is OFF on slave amp • Breaker (Power Switch) tripped <ul style="list-style-type: none"> - Turn off, then turn back on • Rear Power Sequencing Switch is not ON • Error in Sequencing wiring between amplifiers
NO SOUND	Status LED is green. Signal LED is off.	<ul style="list-style-type: none"> • Level Controls turned down • No signal from source • CH B Input Select not set or wired properly
	Status LED is green. Signal LED is green. Limit LED is off.	<ul style="list-style-type: none"> • Poor/broken speaker wiring • Defective speakers
DISTORTED SOUND	Status LED is green. Signal LED is green. Limit LED is off.	<ul style="list-style-type: none"> • Input signal level too high • Poor speaker connections • Low Cut Switch set to Flat • Input Sensitivity Switch not set correctly
	Status LED is green. Signal LED is green. Limit LED is amber (on or flashing).	<ul style="list-style-type: none"> • Speaker transformers saturating at low frequencies, Low Cut filter off, need additional Hi-Pass filtering • Below minimum load rating on output • Exceeding maximum power output rating
INTERMITTENT OPERATION	Status LED is red/green cycling.	<ul style="list-style-type: none"> • DC level at signal input • Load impedance too low • Amplifier speaker output is short-circuited • Amplifier too hot (check for proper ventilation clearances)
NOISE/HUM	Status LED is green. Signal LED is green.	<ul style="list-style-type: none"> • Poor electrical connections at input • Input cable routed near AC cables, power transformer, or other EMI radiating devices • Electrically noisy devices operating on the same AC circuit • Poor equipment grounding <ul style="list-style-type: none"> - Ensure that all AC safety grounds are connected - Make sure that all components in audio chain are tied to the same ground

Specifications

	X600	X450	X300
Power Output*	600W / Ch @ 70V	450W / Ch @ 70V	300W / Ch @ 70V
Input Sensitivity (selectable)	1V/0.1V		
S/N Ratio (20 kHz BW)	104 dB ref. 70V, F.P.		
Class of Operation	H		
Connector: Power	20A line cord**	15A line cord	15A line cord
Input	Pluggable 3-pin terminal strips		
Output	5-pin "touch-proof" Barrier Strip		
Power Bandwidth	20 Hz - 40 kHz, < 0.5% THD		
THD @ 1 kHz Rated Power	less than .02%		
Rated Load Impedance (per Ch.)	8 ohms	11 ohms	16 ohms
Frequency Response @ 1 watt	20 Hz - 20 kHz \pm 0.25 dB		
Output Regulation	1.5 dB @ 70V		
Inputs	100k-ohm electronically balanced, 3-pin pluggable terminal strip		
Low-Cut Filter	60 Hz, 2nd order roll-off, switch defeatable per channel		
AC Input Voltage Range	95-130V AC, 60 Hz		
AC Current Rating (full power)**	20A**	15A	12A
AC Voltage	120V AC, 60 Hz		
Indicators	Status, Limit, Signal, AC Power Status (Rear)		
Temperature Range	15° to 105° F		
Thermal Emissions (Full Power)	1667 BTU/Hr	1537 BTU/Hr	1195 BTU/Hr
Cooling	Dual Forced Air Variable Speed Fan		
Physical Dimensions (W x H x D)	17" W x 3-1/2" H x 18-1/4" D		
Product Weight	46 lb.	44 lb.	41 lb.
Protection	RF, DC, Low frequency, Thermal, Low impedance, Circuit Breaker, Short Circuit		
Special Features	Sequential Turn-On Circuitry (defeatable), Sleep Mode (defeatable), Back-Slope™ AC Voltage regulation, Toroidal Power Transformer, Input Sens, CH B Input Select		

* Both channels driven at nominal line voltage 120V AC, 60 Hz.

** The X600 requires a 20A, 125V AC power receptacle because its maximum current requirements exceed the capacity of a typical 15A receptacle. The receptacle is a NEMA 5-20R style (right).



Limited Warranty; Exclusion of Certain Damages

Bogen Black Max™ amplifiers are warranted to be free from defects in material and workmanship for three (3) years from the date of sale to the original purchaser. Any part of the product covered by this warranty that, with normal installation and use, becomes defective (as confirmed by Bogen upon inspection) during the applicable warranty period, will be repaired or replaced by Bogen, at Bogen's option, provided the product is shipped insured and prepaid to: Bogen Factory Service Department, 50 Spring Street, Ramsey, NJ 07446, USA. Repaired or replacement product will be returned to you freight prepaid. This warranty does not extend to any of our products that have been subjected to abuse, misuse, improper storage, neglect, accident, improper installation or have been modified or repaired or altered in any manner whatsoever, or where the serial number or date code has been removed or defaced.

THE FOREGOING LIMITED WARRANTY IS BOGEN'S SOLE AND EXCLUSIVE WARRANTY AND THE PURCHASER'S SOLE AND EXCLUSIVE REMEDY. BOGEN MAKES NO OTHER WARRANTIES OF ANY KIND, EITHER EXPRESS OR IMPLIED, AND ALL IMPLIED WARRANTIES OF MERCHANTABILITY OR FITNESS FOR A PARTICULAR PURPOSE ARE HEREBY DISCLAIMED AND EXCLUDED TO THE MAXIMUM EXTENT ALLOWABLE BY LAW. Bogen's liability arising out of the manufacture, sale or supplying of products or their use or disposition, whether based upon warranty, contract, tort or otherwise, shall be limited to the price of the product. **IN NO EVENT SHALL BOGEN BE LIABLE FOR SPECIAL, INCIDENTAL OR CONSEQUENTIAL DAMAGES (INCLUDING, BUT NOT LIMITED TO, LOSS OF PROFITS, LOSS OF DATA OR LOSS OF USE DAMAGES) ARISING OUT OF THE MANUFACTURE, SALE OR SUPPLYING OF PRODUCTS, EVEN IF BOGEN HAS BEEN ADVISED OF THE POSSIBILITY OF SUCH DAMAGES OR LOSSES.** Some States do not allow the exclusion or limitation of incidental or consequential damages, so the above limitation or exclusion may not apply to you. This warranty gives you specific legal rights, and you may also have other rights which vary from State to State.

Products that are out of warranty will also be repaired by the Bogen Factory Service Department – same address as above or call 201-934-8500. The parts and labor involved in these repairs are warranted for 90 days when repaired by the Bogen Factory Service Department. All shipping charges in addition to parts and labor charges will be at the owner's expense. All returns require a Return Authorization number. For most efficient warranty or repair service, please include a description of the failure.

12/2008

BOGEN®
COMMUNICATIONS, INC.

50 Spring Street, Ramsey, NJ 07446, USA
Tel: 201-934-8500; Fax: 201-934-9832
www.bogen.com