



Specifications: HP590i

Mounting hardware included

System Type	5.25" Coax, open-ceiling, ported (33 Watt transformer for 25/70.7/100 Volt or voice coil / 8 Ohm direct)
Frequency Response (-3 dB) ¹	75 Hz - 22 kHz
Low Frequency (-10 dB) ¹	60 Hz - 20 kHz
Max. Program Power	160 Watts
Max. Continuous Power RMS ²	80 Watts
Max. SPL dB @ 1 M RMS	109.5 dB
Sensitivity dB @ 1W/1M ³	90.5 dB
Impedance (nominal)	8 Ohm (nominal value)
Coverage Angle (-6 dB @ 2 kHz)	90° (average)
Coverage Angle (-6 dB @ 10 kHz)	90° (average)
Directivity Factor (Q)	5.50 (Averaged 100 Hz - 10 kHz); 8.93 @ 2 kHz
Directivity Index (DI)	5.74 dB (Averaged 100 Hz - 10 kHz); 9.51 dB @ 2 kHz
Tap Selector	6-Position rotary switch with voice coil direct (8 Ohm)

Transformer Taps

70.7 V	Output	100 V	Output	25 V	Output
33 W	105.5 dB	33 W	105.5 dB	5 W	97.5 dB
17 W	103.0 dB	17 W	103.0 dB	2.5 W	94.5 dB
9 W	100.0 dB	9 W	100.0 dB	1.3 W	91.5 dB
6 W	98.5 dB	6 W	98.5 dB	0.63 W	88.5 dB
3 W	95.5 dB				

Transducers	
Low Frequency Driver	1 x 133 mm (5.25 in) Polypropylene cone, butyl rubber surround
High Frequency Driver	25 mm (1.0 in) Convex aluminum horn-loaded tweeter
Low Frequency Voice Coil	25 mm (1.0 in)
Crossover Frequency	3 kHz
Network Type	
Low Pass	N/A
High Pass	12 dB per octave, 2nd order
Enclosure Material	Drawn aluminum backcan with ABS baffle
Motor Board	Cast aluminum
Grille	Iridite-plated steel with powder-coat finish
Inputs	4 Pin, 5 mm Euroblock for individual or daisy chain connection
Colors	Black or white
Height	298.3 mm / 11.74 in
Width (including bracket)	245.9 mm / 9.68 in
Weight	4.3 kg / 9.5 lbs
Shipping Weight	10 kg / 22.0 lbs (2 per box)
Accessories	
Included	Hanging hardware, Euroblock connector & terminal weather boot
Optional	N/A
Packaging	2 Per box, can ship as single

¹ Frequency response is measured in half space and includes a low-frequency peak > +3 dB.

² Continuous power rating, EIA-426-B test.

³ 2.83 Volts at a distance of 1 meter.

SoundTube continually develops new product innovations and improvements. Updates to existing products without prior notice are an example of SoundTube's drive for constant improvement.

Preliminary Technical Information

The information in this document reflects preliminary data. Items including polar plots, frequency, phase & impedance response graphs will be added when final data is available.

Key Features

- High-power output (109.5 dB) for longer throw and higher SPL requirements.
- BroadBeamHP® coverage pattern delivering high-SPL and a consistent 90° dispersion pattern up to 10 kHz (EASE™ documented).
- One 133 mm (5.25 in) polypropylene woofer and one 25 mm (1.0 in) horn-loaded convex aluminum dome tweeter mounted to a proprietary cast-aluminum HP5™ baffle & heat sink.
- 90.5 dB Average sensitivity offers high output capabilities and reduced amplification costs.
- Weatherized components for indoor/outdoor applications.
- Includes hanging hardware with aircraft cables and integrated SpeedClamp™ self-locking wire grip for fast, easy & secure installation. Also includes Euroblock connector & terminal weather boot.
- Easy access 6-position selectable tap switch for 25, 70.7 & 100 Volt applications with voice coil/8 Ohm direct simplifies ordering and inventory tracking.
- High quality black or white paint finish.

Description

The HP590i is a high-powered 5.25" 2-way horn-loaded loudspeaker in a ported open-ceiling enclosure design. The HP590i incorporates a low-profile grille, proprietary HP5™ motor-board and 6-position tap switch with voice coil/8 Ohm direct. Hanging hardware is included and features a fast-action SpeedClamp™ for easy and secure installation.

Applications

Engineered for high-SPL and effective low-end response (60 Hz @ -10 dB), the HP590i delivers consistent foreground music, sound reinforcement and PA for applications requiring longer throw or higher volume. For indoor/outdoor applications, the HP590i incorporates a powder-coated, iridite-plated steel grille, polypropylene driver and durable enclosure design. The HP590i is ideal for

HP590i

Open Ceiling Speaker

Preliminary Technical Information for System Engineers



SOUNDTUBE
ENTERTAINMENT

Frequency Response

N/A

open-ceiling music & paging applications with high ambient noise levels including casinos, warehouses, airports, transportation & shipping centers, schools, gyms, arenas and stadiums. For additional bass, SoundTube's RS801i subwoofer offers bass response to 40 Hz.

Patented SoundTube Technologies

SoundTube Entertainment is consistently developing new technologies that enhance audio product performance. SoundTube Entertainment innovations are protected by multiple U.S. and international patents, which explicitly cover SoundTube dome, enclosure, mounting and dispersion technologies. SoundTube Entertainment actively defends its patents in order to protect SoundTube resellers and end-users.

Phase/Impedance Response

N/A

Beamwidth (-6dB)

N/A

Directivity Index (DI)

N/A



Technical Data and Specification Tools

Technical Data

SoundTube Entertainment strives to provide complete and effective technical information and data to dealers, engineers and designers. All data are available from SoundTube Entertainment or at www.soundtube.com.

Data Acquisition

All performance data acquired at SoundTube's Technical Measurement Center (TMC) are analyzed using a variety of standard measurement techniques, including Measured Length Sequence (MLS) and Time Delay Spectrometry (TDS). Performance, development and data acquisition tools include: Gold Line TEF 20, CLIO, LMS, LEAP, and proprietary modeling software. EASE™ data are acquired through an automated TEF 20/Outline/EASE™ interface.

EASE™ Data – 3-D polar plots.

SoundTubeSPEC™ – Proprietary SoundTube speaker placement software.

Architectural Specifications

The loudspeaker shall consist of a 133 mm (5.25 in) low-frequency transducer and a 25 mm (1 in) high-frequency transducer with a frequency-dividing network installed in a ported enclosure. The low-frequency voice coil diameter shall be 25 mm (1 in).

Performance specifications of a typical production unit shall be as follows: Useable frequency response shall extend from 60 Hz – 22 kHz (-10 dB, no external equalization). Measured sensitivity (2.83 Volt input, 1 meter) shall be at least 90.5 dB. The speaker shall have a nominal impedance of 8 Ohms and shall be available for 25/70.7/100 Volt modes with voice coil/8 Ohm direct. The frequency-dividing network shall have a crossover frequency of 3 kHz with a slope of 12 dB per octave (second order) for the high-pass filter. Rated power capacity shall be at least 80 Watts continuous power (RMS), and conforms to EIA-426-B testing. Maximum continuous output at 1 meter shall be 109.5 dB.

The low-frequency transducer shall have a polypropylene cone with butyl rubber surround. The high-frequency transducer shall be constructed of aluminum material and incorporate a high-SPL 90° horn.

Installation for the HP590i shall be by aircraft cable affixed to the speaker chassis via a carabineer. For seismic & safety redundancy, a secondary aircraft cable shall be included and shall attached to the speaker chassis via a #10 bolt. The external wiring input connector shall be a 4-pin, 5 mm Euro-block for 8 Ohm or distributed systems and shall accept from 10 – 22 gauge wire. The system shall be for indoor & outdoor applications had have a weather-resistant terminal booth covering all wire connectors.

The enclosure shall be constructed of injection-molded glass-reinforced ABS. The grille shall be constructed of iridite-plated, powder-coated steel for lasting performance in the elements. Overall cabinet dimensions shall be no more than 298.3 mm (11.74 in) in height by 245.9 mm (9.68 in) in diameter. The HP590i shall include hanging hardware, Euroblock connector & terminal weather boot.

Polar Plots

N/A

HP590i

Open Ceiling Speaker

Preliminary Technical Information for System Engineers



SOUNDTUBE
ENTERTAINMENT

Mechanical Drawings

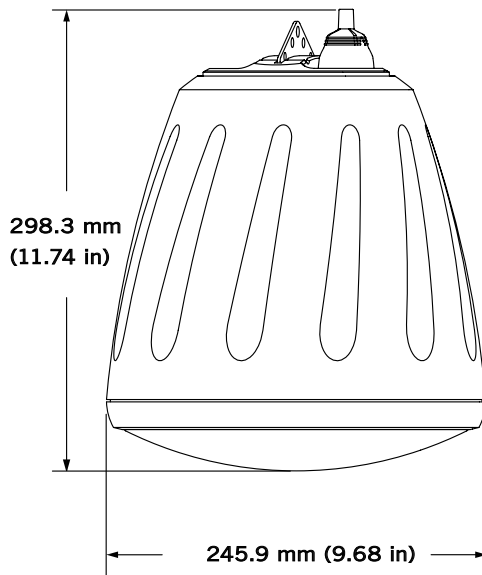

The system shall be the SoundTube HP590i with hanging hardware for both low & high impedance applications.

SoundTube Entertainment

6430 North Business Park Loop
Park City, Utah 84098
Phone 435.647.9555
Fax 435.647.9666
Toll Free 800.647.TUBE
www.soundtube.com

Included Accessories

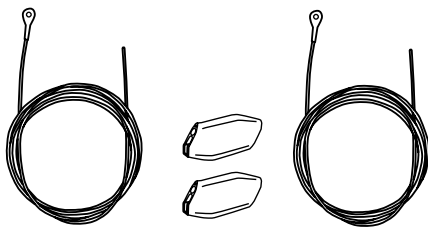

Hanging Hardware: Main & Safety Cables w/ SpeedClamp™

SoundTube's hanging cable kit incorporates hanging & safety cables & SpeedClamp™ self-locking cable clamps for an integrated and easy-to-install system. Hanging & safety cables are infinitely adjustable to 2.74 M (9.0 ft).

SoundTube Entertainment manufactures a complete line of speakers for:
Open-Ceiling • In-Ceiling • Surface-Mount • Outdoor • Sound-Focusing

All SoundTube products are designed and engineered in the USA.